

54870 MTP150 Magnetic Taper



N.W. 2.5kg

Features :

- ▶ Compact and portable design, easy to operate.
- ▶ Guide bar helps the tap positioning precisely.
- ▶ Evenly force-delivering during operation prevent tap from breaking, reducing wear and cost.
- ▶ Quick chuck enables the tap to be easily loaded and unloaded.
- ▶ Powerful permanent-magnet seat, no maintenance needed.
- ▶ Suitable for M4~M12 tape.

Applications

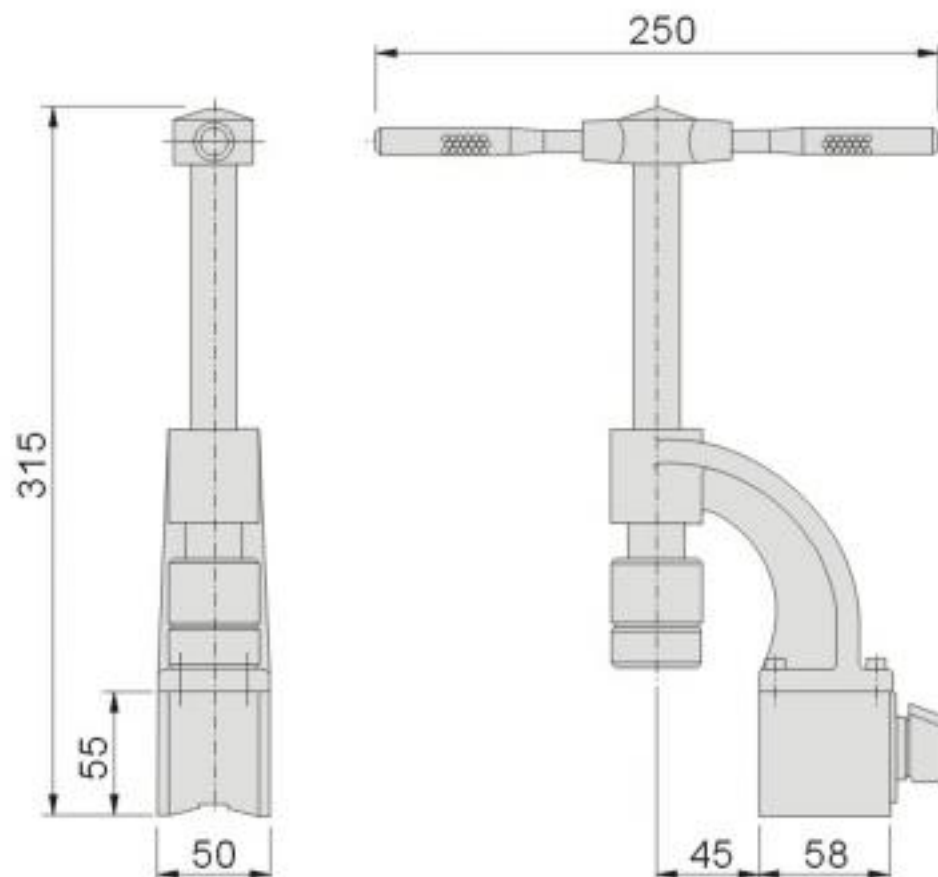

Magnetic Tools

54871

MV120

Magnetic Clamping Block

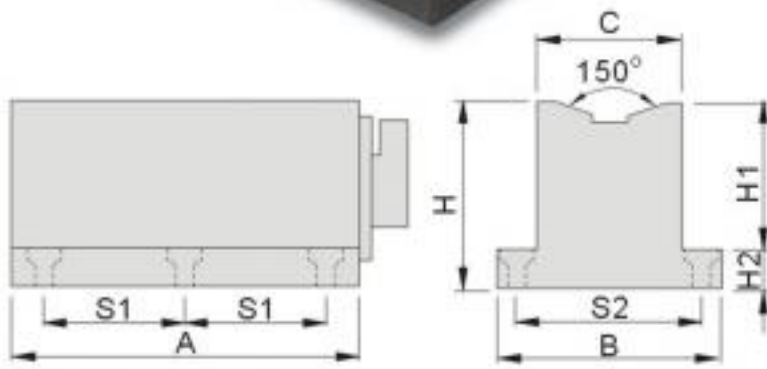

Features :

- ▶ Fast setups of bar stock or round steel.
- ▶ Powerful magnetic base, ON-OFF switch.

Applications:



Unit:mm

Order No.	Model	Mag. Force		Dimension								N.W.
		V-face	Flat	A	B	C	H	H1	H2	S1	S2	
54871	MV120	110kgf	160kgf	118	76	50	62	50	12	48	62	2.5kg

54872

HML100

Powerful Handle Magnet



Features :

- ▶ Easily lifting large and thin steel plate.
- ▶ Separating steel and non-steel and also for screws and nuts.
- ▶ Permanent magnetic guaranteed.

Unit:mm

Order No.	Model	Spec.	Max. Weight	N.W.
54872	HML100	135x30x90	100lbs(45kg)	0.45kg

54873

AHL

Magnetic Safe Catcher



Features :

- ▶ Applying this catcher when operating pressing machines.
- ▶ ON-OFF switch operated by only single hand.
- ▶ Arm length 220mm.

Unit:mm

Order No.	Model	Mag. Spec.	Mag. Force	N.W.
54873-01	AHL-A	∅15x25	0.7kg	0.17kg
54873-02	AHL-B	∅20x25	2.5kg	0.20kg
54873-03	AHL-C	∅25x25	5.0kg	0.25kg

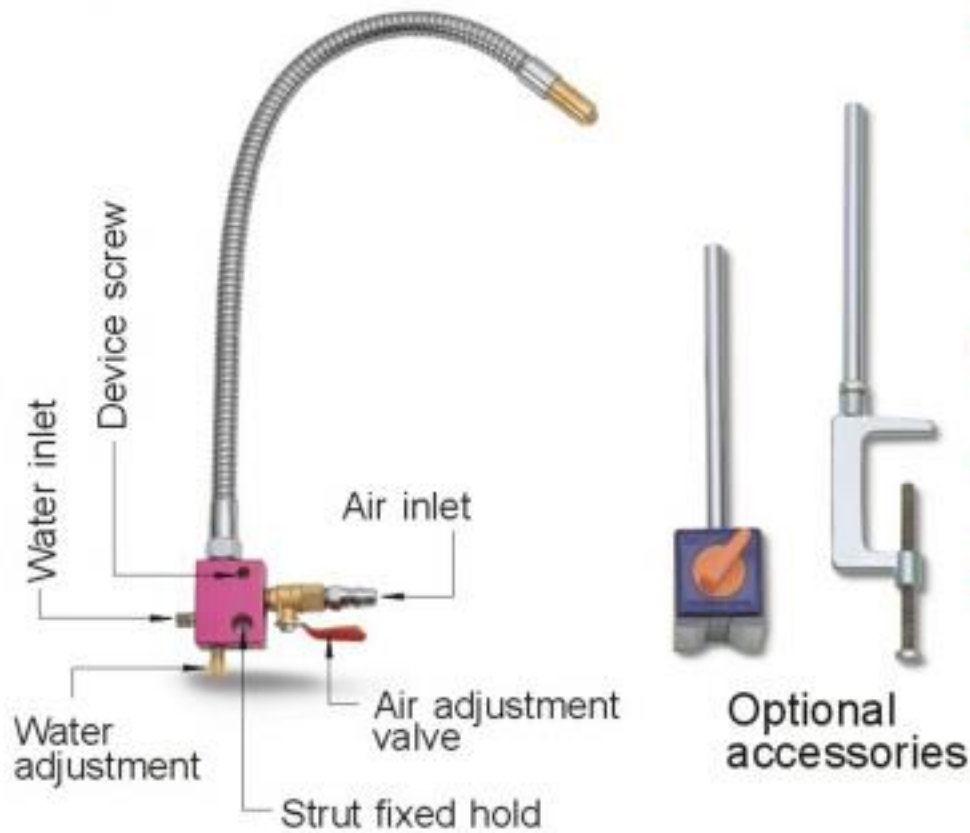
54874
TCT
Multi-function Mist Coolant System

Features :

- ▶ Operating cooling, lubricating and removing metal chips at the same time.
- ▶ Increasing cost effectiveness, efficiency and durability of tools.
- ▶ Ensure better processing quality as well as performance of tools.
- ▶ Assisting better surface finished when processing hard alloy steels.
- ▶ Optional accessories can be used on drill machine and other machines.
- ▶ Random body anodize colour when ordering.

Unit:mm

Order No.	Model	Tube Length	Package size	N.W.
54874-250	TCT-250	250	41x29.5x20cm	0.55kg
54874-500	TCT-500	500	41x29.5x20cm	0.70kg

54876
TCTB
Multi-function Mist Coolant System

Features :

- ▶ Operating cooling, lubricating and removing metal chips at the same time.
- ▶ Increasing cost effectiveness, efficiency and durability of tools.
- ▶ Ensure better processing quality as well as performance of tools.
- ▶ Assisting better surface finished when processing hard alloy steels.
- ▶ Accessories can be used on drill machine and other machines.
- ▶ Magnetic base can be use on any metal surface or machines.
- ▶ Random body anodize colour when ordering.

Unit:mm

Order No.	Model	Tube Length	Package size	N.W.
54876-500	TCTB-500	500	29x16x9cm	1.7kg

Magnetic Tools

54880 PA Magnetic Base Spray Nozzles

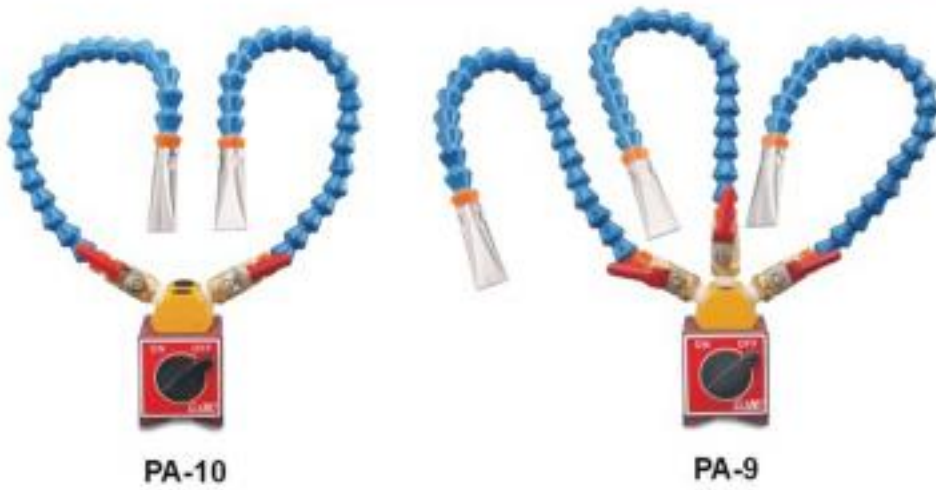

Features :

- ▶ Suitable for drill, milling and grinding machines.
- ▶ Reducing temp. on tools for durability and performance.
- ▶ Easily to locate, tubes are free to adjusted and water volume control.
- ▶ With powerful magnetic base, it can be placed anywhere on steels.

Order No.	Model	Tube Length	Magnetic base spec.			Mag. Force (N)	N.W.
			L	W	H		
54880-01	PA-10	365	60	50	55	80kgf	1.6kg
54880-02	PA-9	365	60	50	55	80kgf	1.62kg

54882 PB Magnetic Base Spray Nozzles

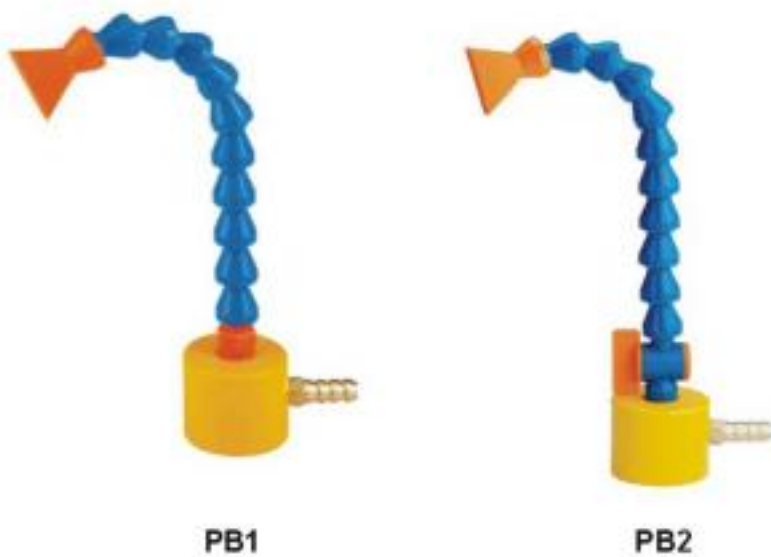

54882-03

PB1(Mag.NO-OFF)

Magnetic base	1set
1/4"segment	10pc
1"Flare Nozzle	1pc
1/4"PT connector	1pc

54882-04

PB2(Mag.NO-OFF)

Magnetic base	1set
1/4"segment	10pc
1"Flare Nozzle	1pc
1/4 Male PT valve	1pc

54884 PC Magnetic Base Spray Nozzles

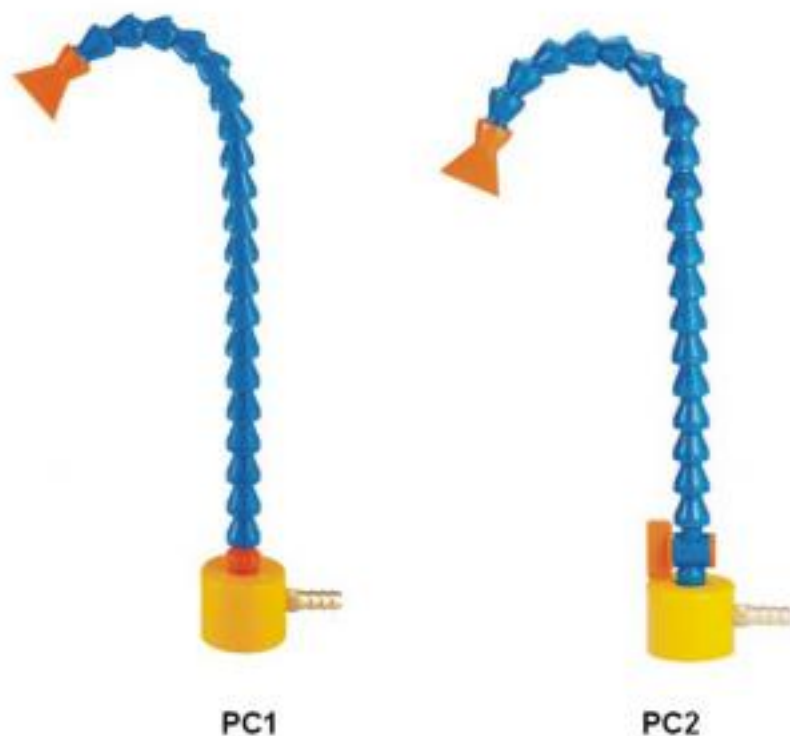

54884-05

PC1(Mag.NO-OFF)

Magnetic base	1set
1/4"segment	20pc
1"Flare Nozzle	1pc
1/4"PT connector	1pc

54884-06

PC2(Mag.NO-OFF)

Magnetic base	1set
1/4"segment	20pc
1"Flare Nozzle	1pc
1/4"Male PT valve	1pc

54886 PD Adjustable Coolant Hoses & Valves



1/4"(36cm Hose Kit)

54886-01 PD1

- 1/4" Male PT or NPT valve
- 1/4" segment 20pcs
- 1/16" or 1/8" or 1/4" Nozzle 1pc



1/4"(36cm Hose Kit)

54886-02 PD2

- 1/4" Female PT or NPT valve
- 1/4" segment 20pcs
- 1/16" or 1/8" or 1/4" Nozzle 1pc



3/8"(36cm Hose Kit)

54886-03 PD3

- 3/8" Male PT or NPT valve
- 3/8" segment 16pcs
- 1/4" or 3/8" or 1/2" Nozzle 1pc



3/8" (36cm Hose Kit)

54886-04 PD4

- 3/8" Female PT or NPT valve
- 3/8" segment 16pcs
- 1/4" or 3/8" or 1/2" Nozzle 1pc



1/2"(35cm Hose Kit)

54886-05 PD5

- 1/2" Male PT or NPT valve
- 1/2" segment 12pcs
- 1/4" or 3/8" or 1/2" Nozzle 1pc



1/2"(35cm Hose Kit)

54886-06 PD6

- 1/2" Female PT or NPT valve
- 1/2" segment 12pcs
- 1/4" or 3/8" or 1/2" Nozzle 1pc

MAGNETIC TOOLS

Magnetic Tools

54890 MD Magnetic Base



N.W.1.1kg

Features :

- ▶ Suitable for applying on dial indicator, LED light, coolant nozzle and diamond tip etc...
- ▶ Mag. Force: 80kgf
- ▶ Magnetic base dimension: (LxWxH) 60mm x 50mm x 55mm

54892 MT Permanent Magnetic Lifter(Handle Type)



Features :

- ▶ Loading Capacity: MT-6S (80 kgf)
MT-10S (160 kgf)

Unit:mm

Order No.	Model	L	W	H	N.W.
54892-01	MT-6S	60	50	55	1.15kg
54892-02	MT-10S	120	50	55	2.00kg

54894 MTT Magnetic Lifter



N.W.2.0kg

Features :

- ▶ New structure design, ON-OFF switch on the subject's surface.
- ▶ Mag. Force: 150kgf
- ▶ Magnetic base dimension: (LxWxH) 140mm x 100mm x 190mm



54896
MH
Magnetic Holder

Unit:mm

Order No.	Model	Mag. Force	Spec.	N.W.
54896-02	MH-18H	5 kgf	∅ 18x8	0.016kg
54896-03	MH-25H	9 kgf	∅ 25x10	0.04kg
54896-04	MH-30R	15 kgf	∅ 30x25	0.11kg
54896-05	MH-40R	30 kgf	∅ 40x30	0.24kg
54896-06	MH-50R	50 kgf	∅ 50x40	0.50kg
54896-07	MH-26S	10 kgf	26x26x25	0.11kg
54896-08	MH-60S	20 kgf	60x26x25	0.25kg

54898
MTB
Magnetic Base

Unit:mm

Order No.	Model	Hole spec.	Magnetic Base Spec.			Mag. Force	N.W.
			L	W	H		
54898-01	MTB35	M5x0.8	35	30	35	25kgf	0.2kg
54898-02	MTB60	M8x1.25	60	50	55	80kgf	1.0kg
54898-03	MTB80		75	50	55	100kgf	1.3kg
54898-04	MTB120		120	50	55	160kgf	2.0kg
54898-05	MTB40	M6x1.0	40	40	40	50kgf	0.6kg

MAGNETIC TOOLS

Magnetic Tools

54900

CZA

Magnetic Indicator Stands



Features :

- ▶ Standard type.
- ▶ Powerful magnetic base.
- ▶ Suitable for applying on dial indicator etc...

Unit:mm

Order No.	Model	Main Lever	Sub Lever	Base spec. L x W x H	Screw hole	Mag. Force	N.W.
54900	CZA-8C	∅12X176	∅10X160	60X50X55	M8x1.25	80kgf	1.4kg

54902

CZB

Magnetic Stands With Fine Adjustment



Features :

- ▶ Fine-tuning type with spring, more flexible.
- ▶ Powerful magnetic base.
- ▶ Suitable for applying on dial indicator etc...

Unit:mm

Order No.	Model	Main Lever	Sub Lever	Base spec. L x W x H	Screw hole	Mag. Force	N.W.
54902	CZB-8C	∅12X176	∅10X150	60X50X55	M8x1.25	80kgf	1.4kg

54904

CZC

Extra Stem Magnetic Indicator Stand With Fine Adjustment



Features :

- ▶ Fine-tuning type with spring, more flexible.
- ▶ One main lever, two sub levers.
- ▶ Powerful magnetic base.
- ▶ Suitable for applying on dial indicator etc...

Unit:mm

Order No.	Model	Main Lever	Sub Lever (middle)	Sub Lever	Base spec. L x W x H	Screw hole	Mag. Force	N.W.
54904-01	CZC-10B	∅20X170	∅14X170	∅12X127	73X50X55	M8x1.25	100kgf	2.0kg
54904-02	CZC-10DL	∅20X350	∅14X165	∅12X129	117X50X55	M10x1.5	130kgf	3.5kg

54916
NHA
High Precision Magnetic Stand

Fine-tuning

Features :

- ▶ New dovetail fine-tuning device, more accurate and stability.
- ▶ Non-magnetic stainless made of main and sub lever.
- ▶ Powerful magnetic base.

Unit:mm

Order No.	Model	Screw hole	Main Lever	Sub Lever	Base spec. L x W x H	Mag. Force	N.W.
54916	NHA	M8X1.25	∅12X175	∅10X160 Fine-tuning	48X40X49	35kgf	1.2kg

Dial indicator please refer Page. D31~32

54918
NHB
High Precision Magnetic Stand

Fine-tuning

Features :

- ▶ New dovetail fine-tuning device, more accurate and stability.
- ▶ Non-magnetic stainless made of main and sub lever.
- ▶ Powerful magnetic base.

Unit:mm

Order No.	Model	Screw hole	Main Lever	Sub Lever	Base spec. L x W x H	Mag. Force	N.W.
54918	NHB	M8X1.25	∅14X200	∅12X165 Fine-tuning	60X50X55	80kgf	1.5kg

54920
NHC
High Precision Magnetic Stand

Fine-tuning

Features :

- ▶ New dovetail fine-tuning device, more accurate and stability.
- ▶ Non-magnetic stainless made of main and sub lever.
- ▶ Powerful magnetic base.

Unit:mm

Order No.	Model	Screw hole	Main Lever	Sub Lever	Base spec. L x W x H	Mag. Force	N.W.
54920	NHC	M10X1.5	∅16X250	∅14X180 Fine-tuning	80X50X55	100kgf	2.3kg

Magnetic Tools

54922

NSA

Mechanical Universal Magnetic Stands



NSA01

NSA02

Dial indicator please refer Page. D31~32

Features :

- ▶ Mini & economic type.
- ▶ Main axle is made of aluminum.
- ▶ Mechanic structure, no leaking oil problem.
- ▶ L1=55,L2=50,L3=30

Unit:mm

Order No.	Model	Base spec. L x W x H	Gauge hole	Mag. Force	N.W.
54922-01	NSA01	35X30X35	8.0 ±0.02	30kgf	0.3kg
54922-02	NSA02				

54925

BS320

Mechanical Universal Magnetic Stands



Features :

- ▶ Medium & economic type
- ▶ Fine-tuning on dovetail clamping.
- ▶ L1=112,L2=102,L3=65

Unit:mm

Order No.	Model	Base spec. L x W x H	Gauge hole	Mag. Force	N.W.
54925	BS320	60X50X55	8.0 ±0.02	80kgf	1.24kg

54926

NSC

Mechanical Universal Magnetic Stands



NSC01

NSC02

Features :

- ▶ Mini & economic type.
- ▶ Fine-tuning structure on base, easy to adjust.
- ▶ Mechanic structure, no leaking oil problem.
- ▶ NSC01 (L1=50,L2=50,L3=65)
NSC02 (L1=55,L2=55,L3=70)

Unit:mm

Order No.	Model	Base spec. L x W x H	Gauge hole	Mag. Force	N.W.
54926-01	NSC01	40X40X40	8.0 ±0.02	50kgf	0.7kg
54926-02	NSC02			50kgf	0.7kg

54927A BS100 Universal Arm Magnetic Base



Features :

- ▶ Mechanical construtere adopted
- ▶ Universal arm can be set at any angle.
- ▶ Fine-tuning dovetail with $\varnothing 8\text{mm}$
- ▶ Suitable for various dial indicators



Fine-tuning dovetail

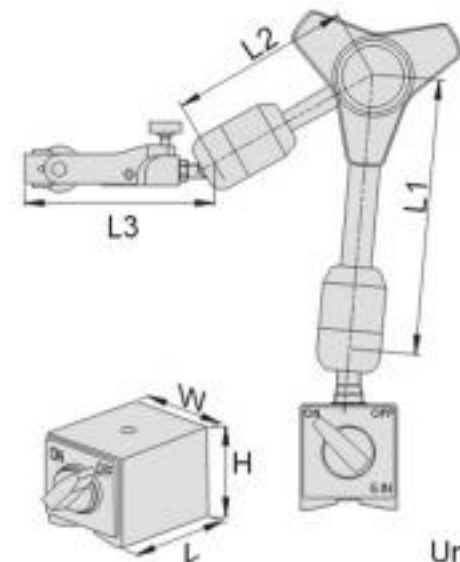

Unit:mm

Order No.	Model	Lever spec.			Mag.base spec.			Mag. Force	N.W.
		L1	L2	L3	L	W	H		
54927A-01	BS100A	62	56	88	40	40	40	50kgf	0.72kg

54927B BS100 Universal Arm Magnetic Base



Features :

- ▶ Mechanical construtere adopted
- ▶ Universal arm can be set at any angle.
- ▶ Suitable for various dial indicators
- ▶ Adopting one-piece fine-tuning dovetail with $\varnothing 8\text{mm}$, no backlash and easily set zero.



One-piece fine-tuning dovetail

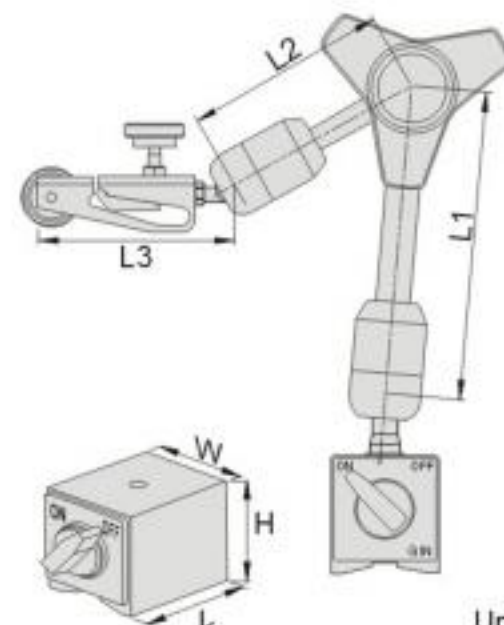

Unit:mm

Order No.	Model	Lever spec.			Mag.base spec.			Mag. Force	N.W.
		L1	L2	L3	L	W	H		
54927B-01	BS100AH	62	56	75	40	40	40	50kgf	0.72kg

Magnetic Tools

54928

NOGA FAT

NOGA Articulated Holders FAT



NF61003 DG61003 MG61003 MA61003

Features :

- ▶ Powerful ON-OFF magnetic base.
- ▶ Central locking mechanism with designed spring.
- ▶ Black finished arms.
- ▶ Universal swivel clamp for all dial and test indicator, holds $\varnothing 6\text{mm}$, $\varnothing 8\text{mm}$, $\varnothing 3/8"$ and $1/4"$ dovetails and back lug.
- ▶ Instant fixation in any position.

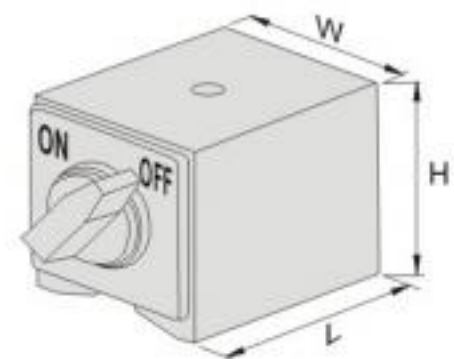
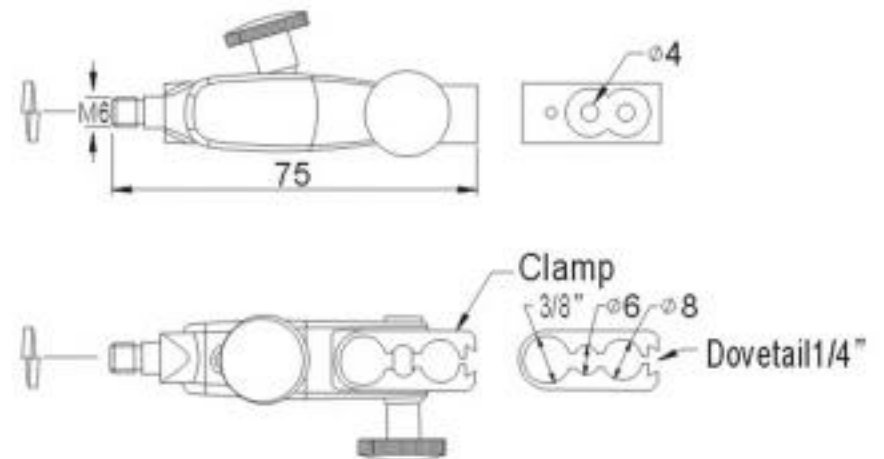
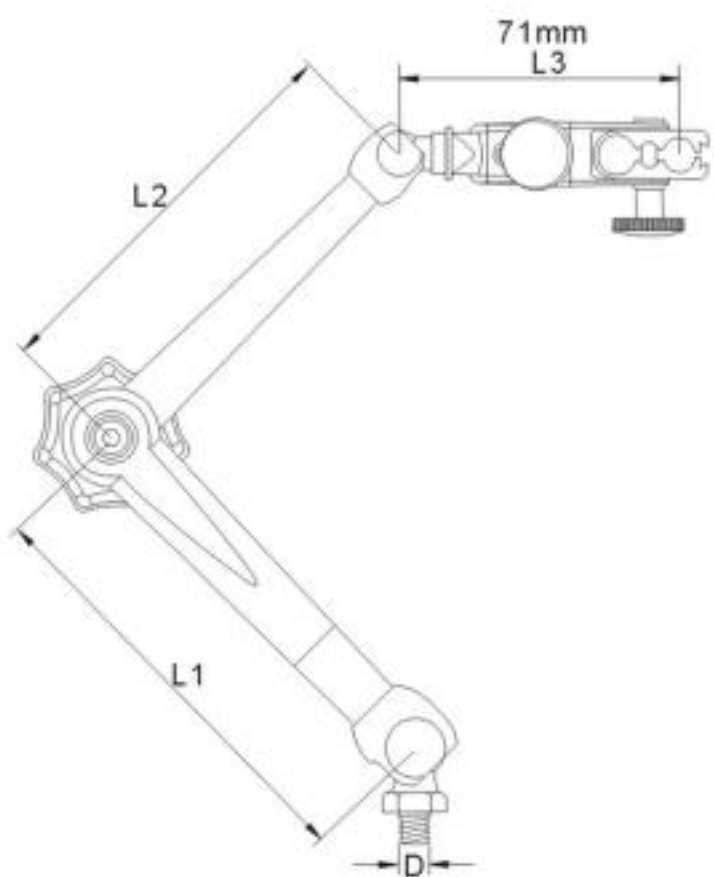

☞ Dial indicator please refer Page. D31~32

Unit:mm

Order No.	Model	Arm length			Magnetic base spec.			Thread	Force (N)	N.W.
		L1	L2	L1+L2+L3	W	H	L			
54928-01	NF61003	56	51	178	30	35	40	Ext.M5	320	0.6kg
54928-02	DG61003	110	101	282	50	55	60	Ext.M8	800	1.4kg
54928-03	MG61003	133	113	317	50	55	60	Ext.M8	800	1.9kg
54928-04	MA61003	286.5	222.5	580	50	55	120	Ext.M10x1.25	1300	5.1kg

54929 BS250 Universal Arm Magnetic Base

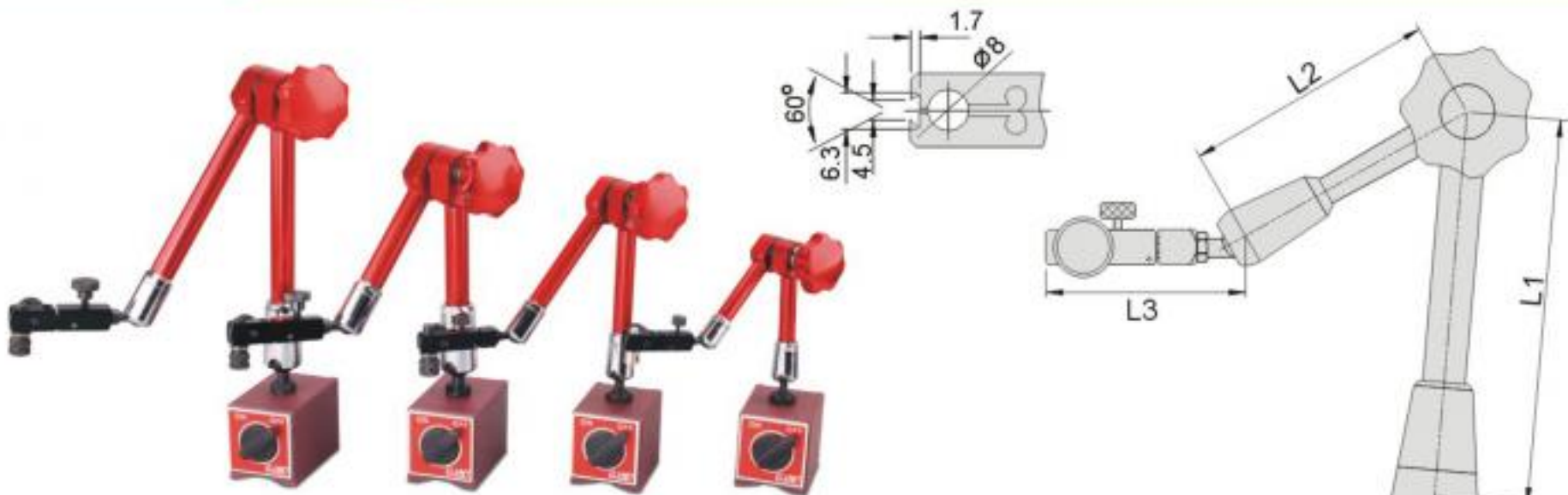

54940 BS350

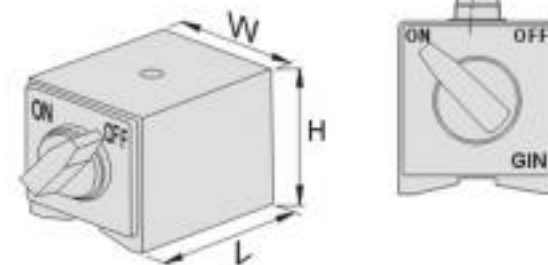

Features :

- ▶ Mechanical construtue adopted
- ▶ Universal arm can be set at any angle.
- ▶ Suitable for various dial indicators
- ▶ Adopting one-piece fine-tuning dovetail with $\varnothing 8\text{mm}$, no backlash and easily set zero.

One-piece fine-tuning dovetail

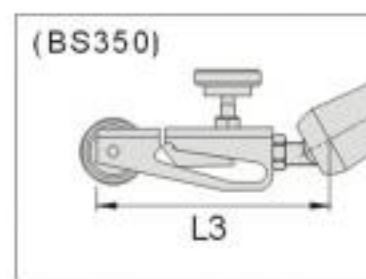

Optional accessory: P.D31

Unit:mm

Order No.	Model	Lever spec.			L3	Mag.base spec.			Mag. Force	N.W.
		L1	L2	L3		L	W	H		
54929-01	BS250S	85	80	60	60	50	55	80kgf	1.28kg	
54929-02	BS250M	120	120	65	60	50	55	80kgf	1.42kg	
54929-03	BS250L	140	125	80	75	50	55	100kgf	1.96kg	
54929-04	BS250LL	190	175	80	75	50	55	100kgf	2.06kg	

Order No.	Model	Arm length			Magnetic base spec.			Force (N)	N.W.
		L1	L2	L3	L	W	H		
54940-01	BS350S	85	80	60	60	50	55	80kgf	1.28kg
54940-02	BS350M	120	120	65	60	50	55	80kgf	1.42kg
54940-03	BS350L	140	125	80	75	50	55	100kgf	1.96kg

Magnetic Tools

54930

BS330

Universal Arm Magnetic Base



BS330L

BS330M

BS330S

Features :

- ▶ Mechanical arm.
- ▶ Powerful ON-OFF magnetic base.
- ▶ Universal swivel clamp for all dial and test indicator.
- ▶ Holds $\varnothing 8\text{mm}$ and $1/4"$ dovetails and back lug.
- ▶ Instant fixation in any position.

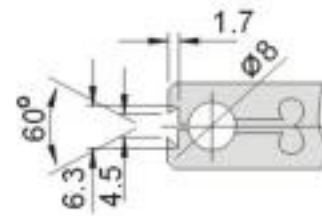

Fine-tuning

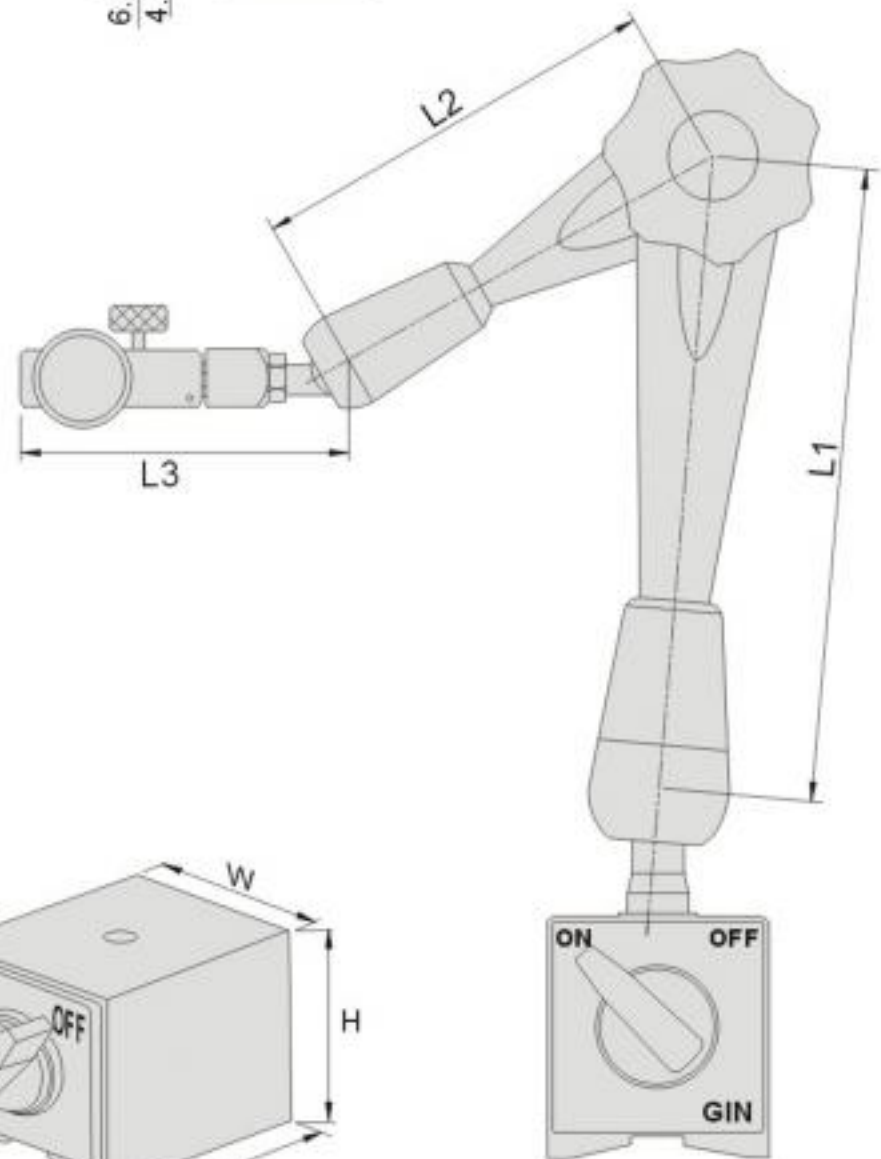

Optional accessory: P.D31
Dial indicator

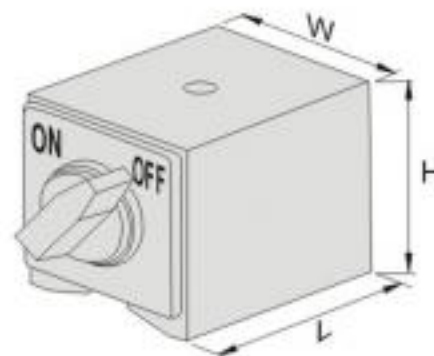

Dial indicator please refer Page. D31~32

Unit:mm

Order No.	Model	Arm length		L3	Magnetic base spec.			Force (N)	N.W.
		L1	L2		L	W	H		
54930-01	BS330S	110	75	65	60	50	55	80kgf	1.5kg
54930-02	BS330M	150	98	65	60	50	55	80kgf	1.7kg
54930-03	BS330L	185	145	70	80	50	55	100kgf	2.2kg

54933
BS333
Universal Arm Magnetic Base

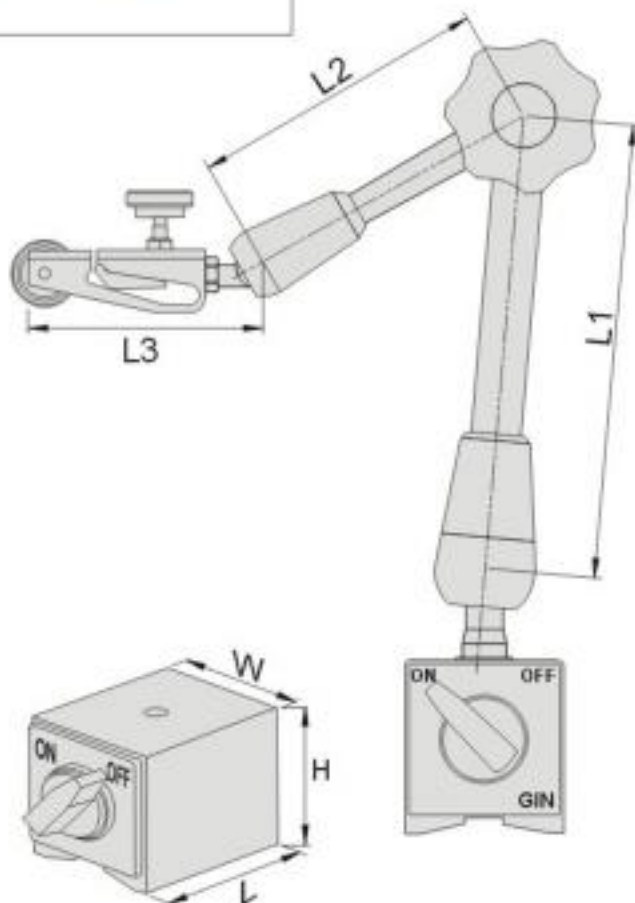
 One-piece
fine-tuning clamping

Features :

- ▶ New locking design with strong clamping force.
- ▶ Made of hardened steel for all the wear parts with HRC58°.
- ▶ CNC machined for main parts.
- ▶ 1/4" dovetail and $\varnothing 8\text{mm}$ holder design for dial gauge.

 Optional accessory: P.D31
Dial indicator

Dial indicator please refer Page. D31~32

Unit:mm

Order No.	Model	Arm length			Magnetic base spec.			Force (N)	N.W.
		L1	L2	L3	L	W	H		
54933-01	BS333SS	62	52	75	40	40	40	50kgf	0.7kg
54933-02	BS333S	100	82	75	60	50	55	80kgf	1.4kg
54933-03	BS333M	145	95	75	75	50	55	100kgf	2.0kg
54933-04	BS333L	175	125	75	75	50	55	100kgf	2.3kg

Magnetic Tools

54934

BS300

Universal Arm Magnetic Base



BS300L

BS300M

BS300S

BS300SS

Features :

- ▶ Precision hydraulic arm.
- ▶ Powerful ON-OFF magnetic base.
- ▶ Universal swivel clamp for all dial and test indicator.
- ▶ Holds $\varnothing 8\text{mm}$ and $1/4"$ dovetails and back lug.

Fine-tuning



Optional accessory:  P.D31
Dial indicator

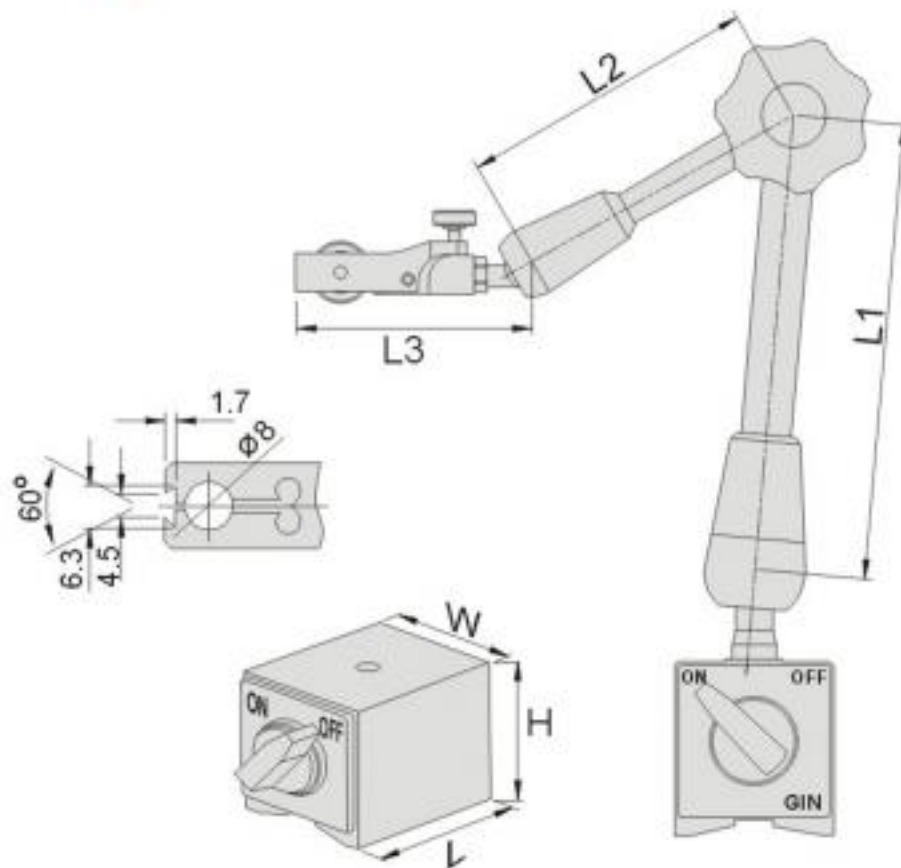

 Dial indicator please refer Page. D31~32

Unit:mm

Order No.	Model	Arm length		L3	Magnetic base spec.			Force (N)	N.W.
		L1	L2		L	W	H		
54934-00	BS300SS	80	80	75	60	50	55	80kgf	1.34kg
54934-01	BS300S	120	118	70	80	50	55	100kgf	1.9kg
54934-02	BS300M	168	166	70	80	50	55	100kgf	2.0kg
54934-03	BS300L	285	280	95	120	50	55	160kgf	3.3kg

54945

BS

Universal Arm Magnetic Base



BS360H

BS340H

BS340

One-piece fine-tuning dovetail



Features :

- ▶ Mechanical construture adopted
- ▶ Universal arm can be set at any angle.
- ▶ Suitable for various dial indicators
- ▶ Adopting one-piece fine-tuning dovetail with $\varnothing 8\text{mm}$, no backlash and easily set zero.

Optional accessory: PD31 Dial indicator

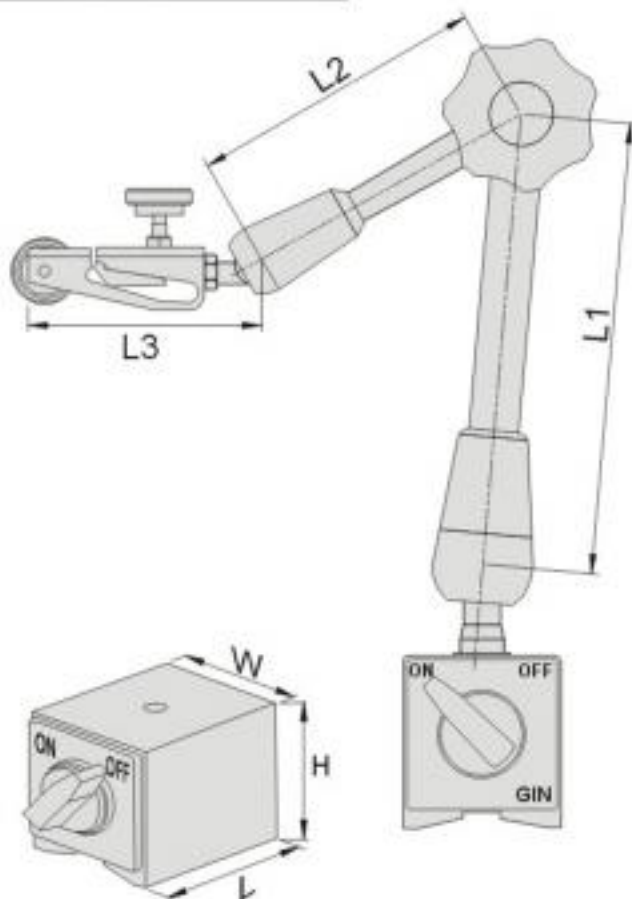

Unit:mm

Order No.	Model	Arm length			Magnetic base spec.			Force (N)	N.W.
		L1	L2	L3	L	W	H		
54945-00	BS340	135	110	65	60	50	55	80kgf	1.58kg
54945-02	BS340H	135	110	65	60	50	55	80kgf	1.58kg
54945-03	BS360H	145	130	70	75	50	55	100kgf	1.96kg

MAGNETIC TOOLS